

Time Required ■■■

Cost ■■■

Skill Level ■■■

By Jesse Hannsen Stratasys, Inc.

OVERVIEW

Spin casting uses centrifugal force to produce parts from a rubber mold. While spinning, casting material is poured into a mold, and centrifugal force pulls the material into the cavities. This accelerates production rates and preserves fine details for castings made of metal, plastic or wax.

In many ways, spin casting is similar to RTV (room temperature vulcanizing) molding. Both processes use rubber molds that reproduce crisp details and accommodate undercuts. Additionally, spin casting and RTV molding offer low-cost tooling and short lead times for part production. Yet, spin casting has some unique advantages over RTV molding.

Because it uses organic or silicone rubber that is heat vulcanized, spin casting molds can be ready for production in just a few hours versus one or two days. The properties of the rubber, combined with the spinning action, also result in extremely short cycle times. For some materials, parts are made in as little as 30 seconds. And a spin casting mold will usually have multiple cavities, so the short cycle time and multiple parts per cycle can yield fairly high production rates.

The heat vulcanized rubber molds can withstand high temperatures. This allows spin casting to manufacture parts in metals (figure 1) with a melt temperature that is less than 1,000 °F (538 °C). The available alloys include zinc, tin, pewter and lead. For these metals, spin casting is the easiest, cheapest and fastest casting method. Spin casting is also an easy, affordable and fast process for making parts in thermoset plastics and foundry wax for investment casting.

Within hours of starting the mold making process, spin casting can churn out metal, plastic and wax parts at a rate of 1,000 to 10,000 a day. With multiple molds, this production rate can more than double. However, before mold making begins, patterns must be made. Traditionally machined from metal, due to vulcanizing temperatures and pressures, the patterns can add days to a process that can be completed in hours.

FDM AND SPIN CASTING

Parts built on a Fortus 3D Production Systems using FDM technology address the need for fast delivery of durable and accurate patterns. By replacing the machined metal patterns, the entire spin casting process, including pattern making, can be completed in as little as one day. FDM is a viable pattern making option because its thermoplastic materials can endure the vulcanizing process. During vulcanization, the mold and its patterns are subjected to temperatures of 300 to 350 °F (149 to 177 °C) and pressures of 800 to 3,500 psi (5.5 to 24.1 MPa) for one to two hours. Fortus PC (polycarbonate) and PPSF (polyphenolsulfone) materials have performed under these conditions.

Like spin casting, FDM produces complex, intricate shapes with no impact on time or cost. Another similarity is the each is capable of producing multiple parts per cycle. These are not characteristics of machined patterns, and this is why FDM is a faster and more cost-effective solution. If a spin casting mold needs 25 patterns that have numerous features, including undercuts, a Fortus system can easily produce them in only a few hours. Another advantage of FDM that is not true of machining or spin casting is that the production process is laborless and automated. While casting parts from one mold, the Fortus system can be working in the background making patterns for the next project. With FDM, spin casting can produce thousands of metal, plastic or wax parts in a single day.

PROCESS OVERVIEW

Molds are formed by placing patterns between disks of uncured rubber. The mold is then loaded into a vulcanizer that applies heat and pressure to cure the rubber. After a few hours, the mold becomes firm yet flexible. The mold is then loaded into a spin casting machine. After the spin

APPLIES TO MATERIALS:

- PC and PPSF

SUPPLIES:

- Rubber disks
- Mold frame
- Locknuts ("acorns")
- Gate/runner preforms
- Mold release
- Casting material

TOOLS AND EQUIPMENT:

- Spin caster
- Three-post vulcanizer
- Furnace (metal melting)
- Modeling tools



Figure 1: Spin casting produces parts in metals with low melt temperatures.

cycle starts, the liquid metal, plastic or wax is poured into the rotating mold. Pressure caused by centrifugal force pushes the liquid through the mold's runner system, completely filling each mold cavity (figure 2). After the material has solidified, the mold is removed, and the castings are extracted.

PROCESS

A spin casting project begins with a mold layout and selection of pattern material. The layout of a spin casting mold will usually consist of multiple parts that are placed symmetrically around the center hub. A mold may be designed to create many copies of the same part or many different parts. This layout will determine the number of FDM patterns required.

Of all the Fortus materials, PC and PPSF are the best suited for pattern making. Due to the temperature and pressure applied to the mold during vulcanization, patterns constructed in other Fortus materials may warp and distort. In general, PPSF will produce the most accurate spin cast parts because of its high heat deflection temperature and mechanical strength. However, it also requires more time and labor for support removal and pattern preparation. PC is more easily finished, but it is slightly less stable in the vulcanizing process, which may translate to larger dimensional deviations.

PATTERN MAKING

FDM patterns can be made from a casting's CAD data with no need for modification. Since the mold is pliable, draft angles do not need to be added to the design and small undercuts do not need to be removed. Optionally, shrinkage compensation can be added to the CAD data prior to exporting an STL file, but this can also be done within Insight.

The shrinkage compensation will vary with the rubber used for the mold and the material that is cast. Refer to supplier information and calculate the net shrinkage for the mold and castings. Scale the STL files by this shrinkage amount. In Insight, orient the patterns for the best surface quality and detail, and then select the solid build style. Any patterns constructed with sparse fill will be subject to collapse when exposed to the pressure of the vulcanizer.

After the build is completed, remove the support structures and finish the patterns to the desired quality level. Since the rubber molds will pick up very small details, it is important to smooth all surfaces to the quality level needed in the cast parts. To achieve the desired finish, use a combination of DCM (methylene chloride) dipping (PC only), sanding, filling and priming.

MOLD MAKING

The spin casting mold begins as pre-formed, uncured rubber disks that have a consistency similar to modeling clay. The type of rubber—organic or silicone—is selected based on the material to be cast, type of part and desired production quantities.

The rubber disks are stacked to the desired thickness for the core side of the mold. The patterns are then arranged in a balanced, symmetrical pattern to ensure even material distribution (figure 3). Each pattern is then aligned such that material can be easily pulled through the cavity. Typically, this orientation has the longest side of the part along a radial line from the hub.

Once placed and aligned, the patterns are then embedded in the rubber to define the parting line for the cast part. For flat bottomed parts, the patterns are laid on top of the rubber. For all others, a shallow pocket is cut into the rubber. The pattern is then set into the pocket, and the excess rubber is shaped around it to establish the parting line.

Next, insert a center plug into the middle of the rubber disc to create the sprue. Then arrange locknuts or pins on the perimeter to ensure proper alignment of the two mold halves when assembled for casting. Optionally, preforms for the runner system may also be placed into the mold. The core side of the mold is now complete. Place the core side in a circular mold frame, and spray the surface with mold release. To complete the mold, stack additional uncured rubber discs on top of the core side of the mold. This will be the cavity side of the mold.

MOLD VULCANIZING

The vulcanizer consists of two heated platens mounted on a hydraulic press. The heat and pressure of the vulcanizer cause the uncured rubber to flow around the patterns and fill the voids. As the exposure to elevated temperatures continues, the rubber begins to cure, which causes it to become firm yet flexible.

The uncured rubber mold containing the patterns is placed into the vulcanizer (figure 4), which is preheated to 315 °F (157 °C). The pressure is then slowly raised to approximately 1,000 psi (6.9 MPa) to squeeze the halves of the mold. The pressure and temperature, which vary by type of rubber, are maintained for one to two hours.

When vulcanizing is complete, the mold is removed. After a short cooling period, the mold

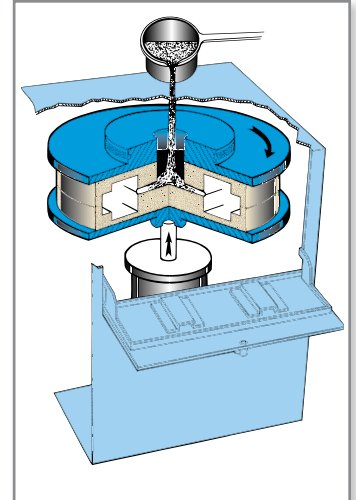

Figure 2: Metal, plastic or wax is poured into a rotating mold. Centrifugal force pushes the material into the mold cavities.



Figure 3: Patterns, center plug and locknuts are placed on the uncured rubber disk.



Figure 4: The mold is loaded into a vulcanizer that cures the rubber.

frame is taken off, and the two halves are separated. The patterns, and any metal preforms, are then extracted from the mold. Gates, runners and vents are now cut into the cured rubber (figure 5) with a sharp knife or scalpel. Typically, each is a V-shaped channel. The gates and runners feed casting material to the part cavity from the central hub. The vent allows air in the cavity to escape so that back pressure does not cause a partial fill of the mold cavity. The mold is now ready for spin casting.

CASTING

Apply mold release to both sides of the rubber mold, close the mold and place it in the spin casting machine (figure 6). Prior to starting the spin casting machine, prepare the casting material. If casting metal, melt the material in a gas or electric furnace. Bring the molten alloy to the ideal casting temperature. If the metal is too cold, it will freeze off before filling the mold, and if too hot, it will degrade the mold prematurely. When casting foundry wax, melt the material in a suitable melting tank or pot. For thermoset materials, combine the two parts of the material kit and stir thoroughly.

To prepare the spin caster, select the rotational speed, clamping pressure and cycle time. Each variable will be dependent on the material that is cast. For example, metals will have a cycle time of less than one minute, while plastics will have a duration of five to 10 minutes.

Start the spin caster, and as the mold is spinning, pour the casting material into the funnel at the top of the machine (figure 7). When the cycle is complete, remove the mold from the spin caster.

FINISHING

Separate the two halves of the rubber mold to expose the castings (figure 8). To extract them, flex the rubber or gently pry the casting from its cavity. If any material remains in the gate, runner or vent channels, remove it prior to reusing the mold. Finish the casting by snapping the gates off of the part and grinding or sanding the remainder. The castings are now ready for painting, plating or use.

CONCLUSION

For metal, plastic and wax parts, spin casting is a simple, affordable and fast method for prototyping or production. With FDM, the same can be said of the pattern-making process. Within hours, molds can be made and parts can be cast.

SUPPLIERS

Tekcast Industries, Inc. (www.tekcast.com). All images courtesy of Tekcast Industries, Inc.



Figure 5: Gates, runners and vents are cut into the rubber mold with a sharp knife or scalpel.



Figure 6: The mold is loaded into the spin casting machine.



Figure 7: While spinning, molten metal is poured into the mold.



Figure 8: After the metal has cooled, separate the mold to expose the castings.

FDM PROCESS DESCRIPTION

Fortus 3D Production Systems are based on patented Stratasys FDM (Fused Deposition Modeling) technology. FDM is the industry's leading Additive Fabrication technology, and the only one that uses production grade thermoplastic materials to build the most durable parts direct from 3D data. Fortus systems use the widest range of advanced materials and mechanical properties so your parts can endure high heat, caustic chemicals, sterilization, high impact applications.

The FDM process dispenses two materials—one material to build the part and another material for a disposable support structure. The material is supplied from a roll of plastic filament on a spool. To produce a part, the filament is fed into an extrusion head and heated to a semi-liquid state. The head then extrudes the material and deposits it in layers as fine as 0.005 inch (0.127 mm) thick.

Unlike some Additive Fabrication processes, Fortus systems with FDM technology require no special facilities or ventilation and involve no harmful chemicals and by-products.

For more information about Fortus systems, materials and applications, call **888.480.3548** or visit www.fortus.com

Fortus 3D Production Systems
Stratasys Incorporated
7665 Commerce Way
Eden Prairie, MN 55344
+1 888 480 3548 (US Toll Free)
+1 952 937 3000
+1 952 937 0070 (Fax)
www.stratasys.com
info@stratasys.com

Fortus 3D Production Systems
Stratasys GmbH
Weismüllerstrasse 27
60314 Frankfurt am Main
Germany
+49 69 420 9943 0 (Tel)
+49 69 420 9943 33 (Fax)
www.stratasys.com
europe@stratasys.com

For more information about Fortus systems, materials and applications, call **888.480.3548** or visit www.fortus.com

Fortus 3D Production Systems
Stratasys Incorporated
7665 Commerce Way
Eden Prairie, MN 55344
+1 888 480 3548 (US Toll Free)
+1 952 937 3000
+1 952 937 0070 (Fax)
www.stratasys.com
info@stratasys.com

Fortus 3D Production Systems
Stratasys GmbH
Weismüllerstrasse 27
60314 Frankfurt am Main
Germany
+49 69 420 9943 0 (Tel)
+49 69 420 9943 33 (Fax)
www.stratasys.com
europe@stratasys.com

©2009 Stratasys Inc. All rights reserved. Stratasys and FDM are registered trademarks and Fortus, Real Parts, Fortus 200mc, Fortus 360mc, Fortus 400mc, Fortus 900mc, Insight, Control Center and FDM TEAM are trademarks of Stratasys Inc., registered in the United States and other countries. *ULTEM 9085 is a trademark of SABIC Innovative Plastics IP BV. All other trademarks are the property of their respective owners. Product specifications subject to change without notice. Printed in the USA.

FORTUS[™]
3D PRODUCTION SYSTEMS